

**PLAN (ABOVE)**

ACCORDION BLADES  
HELD OPEN WITH 165  
DEGREE FUSIBLE  
LINK ASSEMBLY.

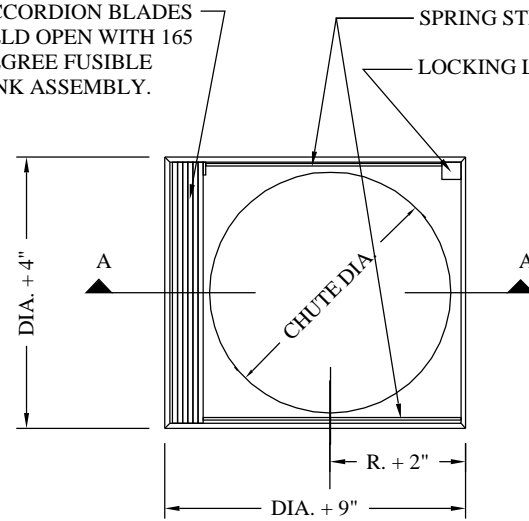

**PLAN (INSIDE)**

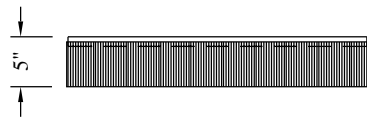

**SIDE ELEVATION**

ACCORDION BLADES  
HELD OPEN WITH 165°F  
FUSIBLE LINK ASSEMBLY.

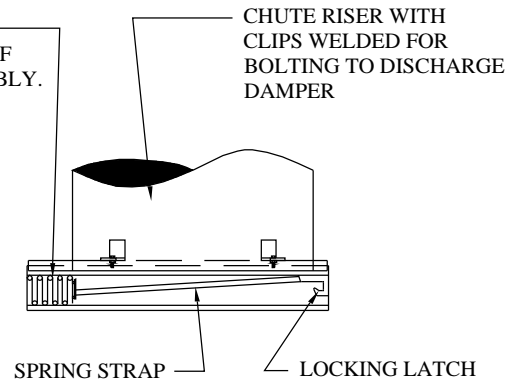

**SECTION A-A**

**NOTE:**

THIS DRAWING IS THE PROPERTY OF CHUTES International Manufacturing AND IS LOANED ON THE CONDITION THAT IT IS NOT TO BE REPRODUCED AND IS NOT TO BE USED IN WHOLE OR PART TO FURNISH INFORMATION FOR THE MAKING OF DRAWINGS OR DISCHARGES.

**TYPICAL  
ACCORDION FIRE  
DAMPER DISCHARGE**

The horizontal direct type accordion door is most commonly used when discharging directly into a bin or compactor. The damper bears a 1 1/2 hr. UL label and is held open on a 165° fusible link assembly. This door is intended to provide smoke and fire protection to the chute riser and is not designed to perform as a shut off gate.

**CHUTES**  
INTERNATIONAL  
MANUFACTURING

Phone: (301) 753-4100  
Toll Free: 800-88-CHUTE  
Fax: (301) 753-4109  
4400 Austin Lane  
White Plains, MD 20695  
WWW.CHUTES.COM