

SIDE VIEW

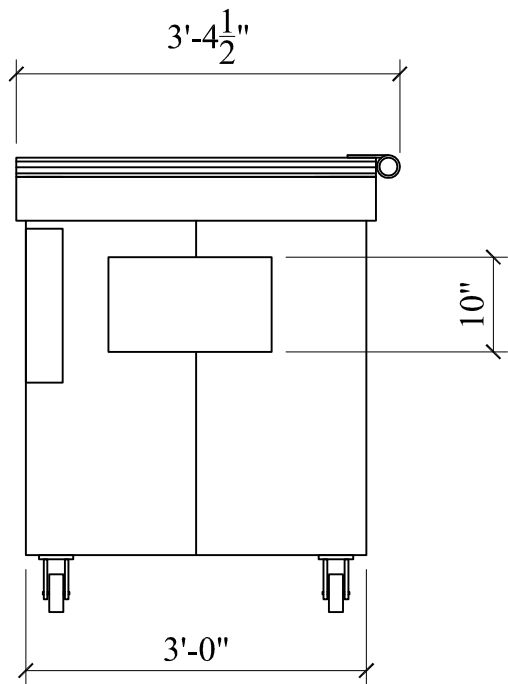

SIDE VIEW

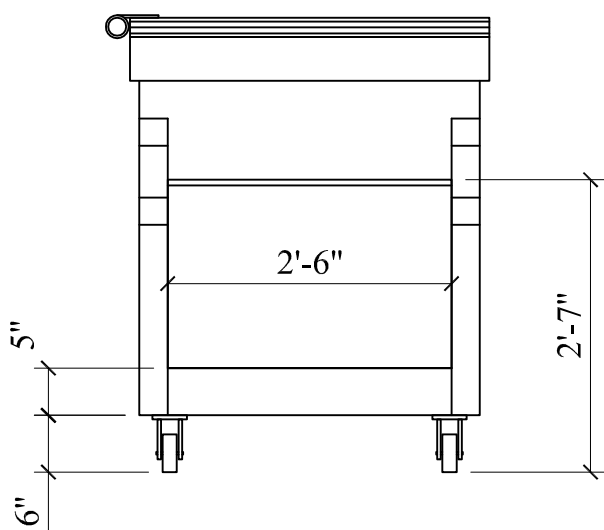

SIDE VIEW

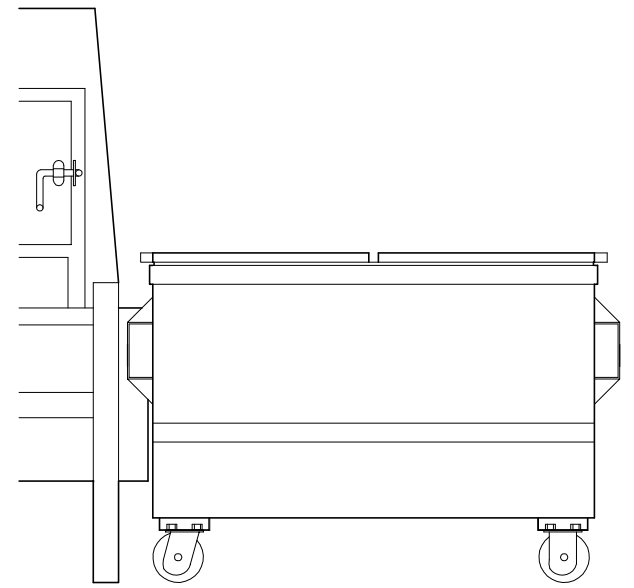

NOTE:

1. THIS DRAWING IS THE PROPERTY OF CHUTES International MANUFACTURING AND IS LOANED ON THE CONDITION THAT IT IS NOT TO BE REPRODUCED AND IS NOT TO BE USED IN WHOLE OR PART TO FURNISH INFORMATION FOR THE MAKING OF DRAWINGS OR CANS.
2. REMOVE ALL WELD SPLATTER
3. GRIND SMOOTH ALL SHARP AREAS.

MATERIALS

1. SIDES - 12 GA. STEEL
BOTTOM - 10 GA. STEEL
LDS - 14 GA. STEEL
POCKETS - 7 GA. STEEL
CASTER PADS - 10 GA. STEEL
CHANNELS - 10 GA. STEEL
CHARGING DOOR - 10 GA. STEEL
REINFORCING CHANNEL @ CASTER - 3/16" STEEL
RISER - 10 GA. STEEL

PICK UP OPTION:

2. FRONT LOAD PICK UP
- REAR LOAD PICK UP

1ST SUBMITTAL		
RESUBMITTAL		
APPROVED FOR FAB.		

Job Name:	
Customer:	
Location:	
Item:	2 CUBIC YARD COMPACTOR CAN

PO No.		JOB No.	
--------	--	---------	--

CHUTES
INTERNATIONAL
MANUFACTURING

Phone: (301) 753-4100
Toll Free: 800-88-CHUTE
4400 Austin Lane
White Plains, MD 20695
WWW.CHUTES.COM