

LEFT VIEW

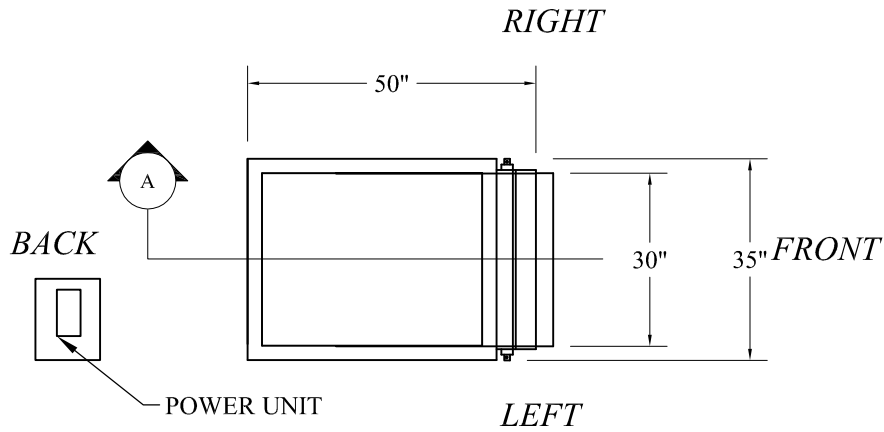

TOP VIEW

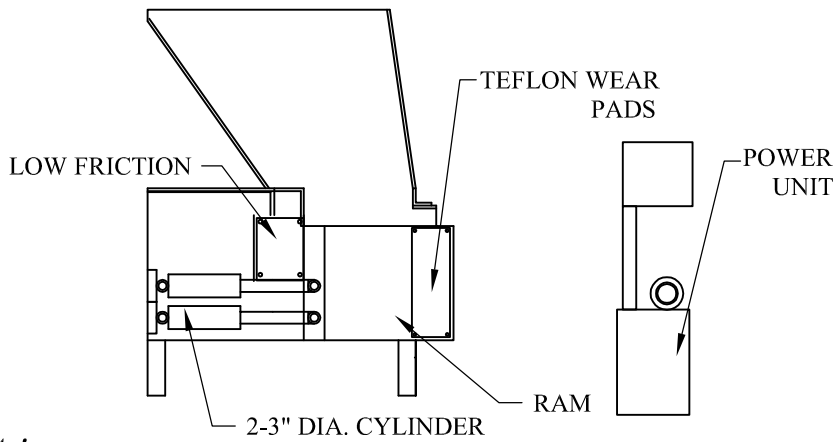

SECTION 'A'

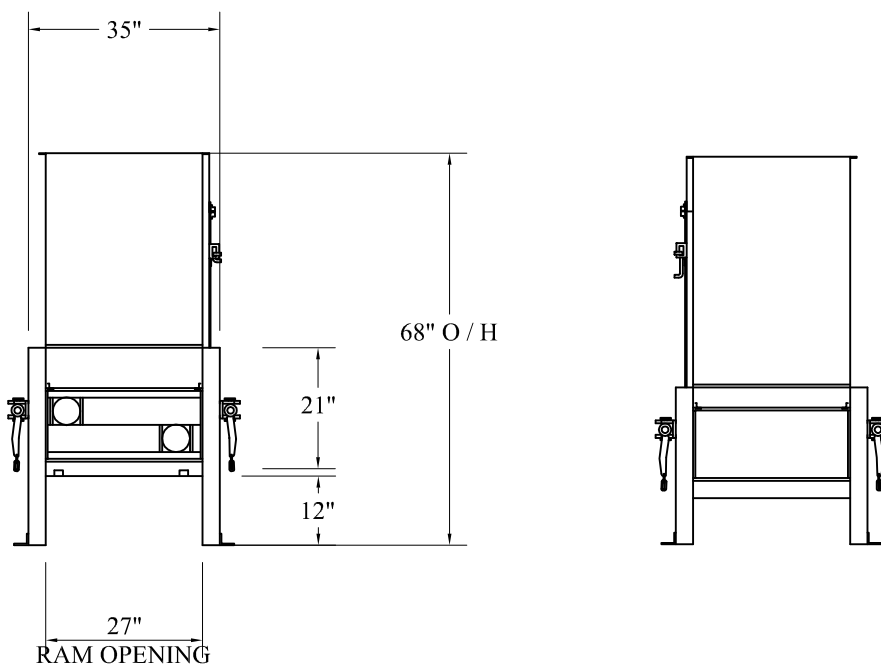

REAR VIEW

FRONT VIEW

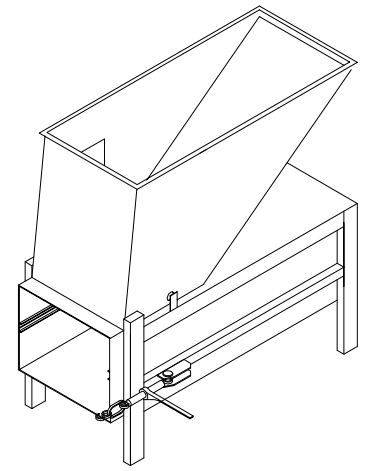

NOTE:

1. THIS DRAWING IS THE PROPERTY OF CHUTES International MANUFACTURING AND IS LOANED ON THE CONDITION THAT IT IS NOT TO BE REPRODUCED AND IS NOT TO BE USED IN WHOLE OR PART TO FURNISH INFORMATION FOR THE MAKING OF DRAWINGS OR COMPACTORS.

1	WEIGHT : 1500 LBS CYCLE TIME : 45 SECONDS APPROX.
2	<u>STRUCTURE</u> SIDE STRUCTURE : 1/4" C.R. STEEL BOTTOM OF COMPACTOR : 1/4" WITH 1/4" WEAR PLATE BOTTOM / FRONT OF RAM : 3/8" C.R. STEEL
3	HOPPER EXTENSION TO BE FABRICATED OF 10 ga. COLD ROLLED STEEL.
4	TEFLON WEAR PADS ON RAM SIDES
5	ELECTRICAL CONTROLS; AUTOMATIC EYE; ON / OFF SELECTOR SWITCH, FULL INDICATOR LAMP.
6	14 GALLON HYDRAULIC OIL TANK 4" DIA. X 32" STROKE CYLINDER 1750 P.S.I. NORMAL PRESSURE 4 G.P.M. PUMP 5 H.P. ELECTRICAL MOTOR; FLA 13 AMP 208, 3 PHASE, TYPICAL.
7	ACCESS DOOR WITH SAFETY INTERLOCK SWITCH (LEFT SIDE ACCESS DOOR, TYPICAL)
8	AUTOMATIC SHUT DOWN WHEN CONTAINER IS FULL
9	POWER UNIT 5 HP MOTOR 14 GALLON HYDRAULIC OIL RESEVOIR "UL" LISTED CONTROL PANEL ON/OFF KEY SWITCH

-PLEASE VERIFY ACCESS DOOR LOCATION:

- LEFT
- RIGHT

-PLEASE VERIFY POWER REQUIREMENT.

- 208V, 3 PHASE
- 230 V, 3 PHASE
- 480V, 3 PHASE
- 120V, SINGLE PHASE, 2HP

1ST SUBMITTAL		
RESUBMITTAL		
APPROVED FOR FAB.		

Job Name:	
Customer:	
Location:	
Item:	DURAPAK 130-HD SHORT BODY COMPACTOR

PO No.		JOB No.	
--------	--	---------	--

CHUTES
INTERNATIONAL
MANUFACTURING

Phone: (301) 753-4100
Toll Free: 800-88-CHUTE
4400 Austin Lane
White Plains, MD 20695
WWW.CHUTES.COM